

INTERLAKEN

WELL ONLY SELF-SERVICE INTEGRAL CABINET





INTERLAKEN

WELL ONLY SELF-SERVICE INTEGRAL CABINET

Transparency, lightness and efficiency are the distinguishing features of Interlaken which is designed to combine advanced display solutions and high loading capacity.



Benefits & Specifications:

- User-friendly
- Small footprint with compact design
- Easy access and ergonomic design
- Customized solutions for individual needs
- Fully configurable to different concepts
- Easily adaptable to seasonal needs
- Low operating costs
- Simplified maintenance
- Wide range of future/ refrigerant options



Dimensions (mm):

Height : 1014
Length : 1360
Depth : 1009

SYSTEM	OPERATING TEMP. °C	REFRIGERANT
PLUG-IN	+2 / +4	HC HFC blend HFC / HFO blend

HC: R290 / R1270 • HFC: R407A / R407F / R134a / R404A • HFC / HFO: R448A / R449A / R452A / R450A



TECHNICAL DATA

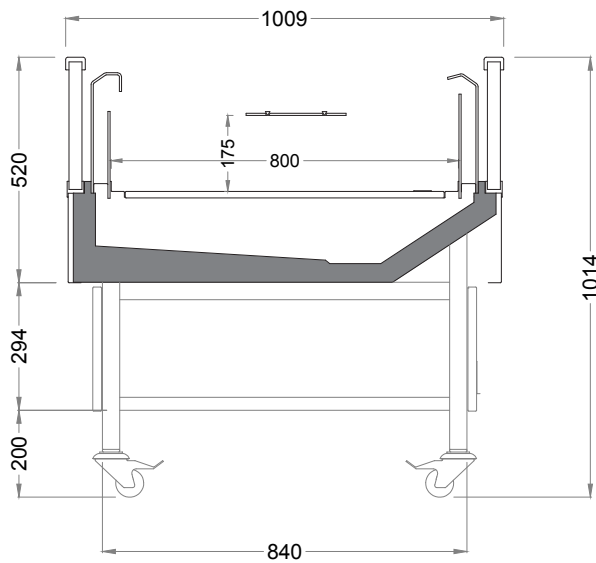

INTERLAKEN

Length mm | 1360 (with endwalls)

STAY COOL & KEEP FRESH

