



# CITRINE ORIEL

SERVE - OVER COUNTER



### Benefits & Specifications:

- Oriel display for niche products
- Eye-catching presentation for discerning customers
- Revolving tray for highlighted products
- Adds dynamic perspective

### Dimensions (mm):

Height : 1200  
 Length : 1250  
 Depth : 1489

SYSTEM	OPERATING TEMP. °C	REFRIGERANT
REMOTE	+2 / +4	HFC blend HFC/HFO blend CO <sub>2</sub> Glycol / Water

HFC: R407A / R407F / R134a / R404A • HFC/HFO: R448A / R449A / R452A / R450A  
 CO<sub>2</sub>: R744 • GLYCOL/WATER: R718



## TECHNICAL DATA

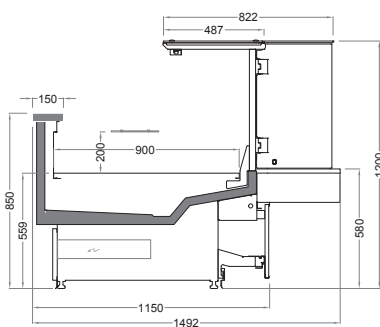

**CITRINE 900 / 1200 / 1150 / 580-SQ-AA**

Length mm | 1250

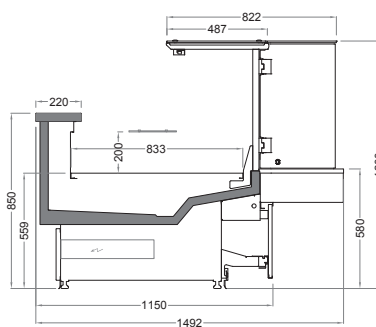

**CITRINE 830 / 1200 / 1150 / 580-SQ-AA**

Length mm | 1250

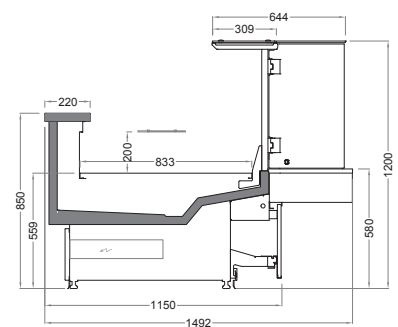

**CITRINE 830 / 1200 / 1150 / 580-SQ-D**

Length mm | 1250

# STAY COOL & KEEP FRESH

